

Weatherproof VoIP-Telephone InduTel IP

Telephone for indoor and outdoor applications with protective door



Overview

The telephone InduTel IP by FHF is characterized by an elegant design for indoor uses as well as a high resistance for uses in outdoor facilities with non-explosive environments.

The InduTel IP is the ideal device for a number of different operation sites – no matter if exposed to seawater, high humidity or extensive mechanical strain.

Thanks to the protective door, the handset and keypad are always perfectly protected against contamination.

The administration of the InduTel IP is carried out using the FHF Webserver.

Features

- Ingress protection IP 66 according to IEC60529
- Ambient temperature -40 °C to +55 °C
- Protocol: SIP (RFC3261)
- Codecs: G.711 A-Law, G.711 μ -Law
- RJ45 (10/100 Mbit/s)
- With internal relay contact
- Power over Ethernet or 24 VDC-48 VDC
- Optical call indication
- Illuminated keypad



Powering Business Worldwide

General arrangement drawing (all dimensions in mm)

Specifications

Power supply	PoE according to IEEE 802.3af or 24 to 48 VDC
Power consumption	1.3 Watt
Connection	LAN RJ45 (10/100 Mbit/s)
Relay contact	Up to 30 VAC or 60 VDC 2 A < 30 VDC 1 A > 30 VDC 1 A < 30 VAC
Protocol	SIP (RFC3261)
Ringing volume	with open housing cover approx. 90 dB(A) in 1 m distance with open housing cover approx. 65 dB(A) in 1 m distance
Housing Material	Polycarbonat
Height x width x depth	330 x 237 x 110 mm
Weight	2.3 kg (telephone incl. telephone bracket)
Operating position	Vertical wall mounting
Receiver Mouthpiece	Elektret microphone
Earpiece	Dynamic capsule
Cable gland	2x M16 x 1.5 for cable diameters 5-9 mm
Optical call indication and illuminated keypad	May be enabled/disabled
Ambient temperature Operation	-40 °C to +55 °C
Transport and storage	-40 °C to +70 °C
Ingress protection	IP 66 acc. to IEC 60529 (with protective door closed)

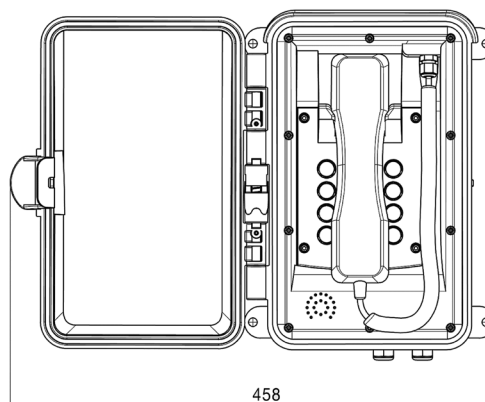
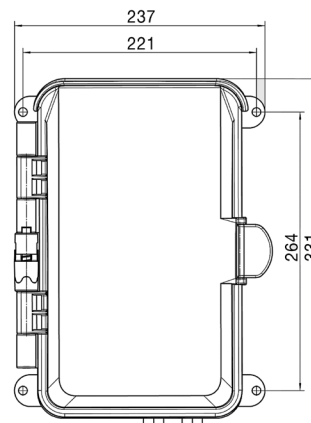
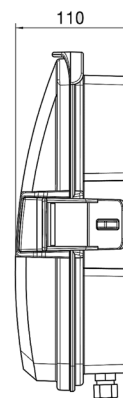

Ordering data

Type	Designation	Colour	Article number*
InduTel IP	Wall telephone with protective door, transparent	yellow	FHF 112 645 86
InduTel IP	Wall telephone with protective door, transparent	red	FHF 112 645 86 02

Terminal assignment

